

# Byram Laboratories' SM23 Smart Meter



Byram's smart meters are electronic electricity meters designed to meet residential metering requirements and provide remote communications. As a component of the EnergyAxis® System, our smart meters bring advanced metering infrastructure capabilities to residential metering applications. Utilities can obtain interval data, bidirectional energy, critical tier, and time-of-use (TOU) data through the EnergyAxis® network. Byram's smart meters are available in most common residential wiring configurations

## Outage and Restoration Functionality

Byram's smart meters provide advanced outage and restoration support, enhancing the ability to more quickly identify the scope of outages and to receive positive restoration messages to validate that power has been restored to every endpoint.

Features include the following:

- Count of momentary and sustained outages
- Total cumulative time of sustained outages
- Outage time and date stamp
- Qualified restoration notification with service voltage

## Key Features

- Proven 2-way communications using EnergyAxis® 900 MHz FHSS RF technology, providing the ideal combination of speed, penetration, and RF power.
- 3 Demand quantities with 5-, 15-, 30-, or 60-minute block demand, including remote demand reset and demand limiting.
- 2 Channel interval data collection with EOI energy snapshot for improved data validation.
- Support for ANSI C12.19 and C12.22.
- Support for 4-tier, 4-season, time-of-use energy and demand with critical tier pricing.
- On request energy, demand, status, and instrumentation data read support.
- Quick and easy to install.
- UL recognized safety.
- 2 Configurable metered quantities supporting bidirectional metering, ideal for net metering and co-generation applications.
- Future upgradability with over the air firmware upgrades.
- Advanced energy theft and meter tampering detection technology.
- Advanced security with full 128-bit AES encryption.

# Over the Air Upgrades

Using proven code management architecture, Byram's smart meter technology allows remote upgrade of meter and communications firmware while ensuring that endpoint network functionality remains intact without loss of metering data. Remote upgradability of the entire firmware image protects your investment and allows you to meet future requirements of the smart grid without concern of technology obsolescence. In addition to remote firmware upgradability, the meter also supports remote reconfiguration of many metering parameters.

## Specifications

### Voltage

1 phase, 3 wire network 120/208 VAC  $\pm$  20%

Current 200A

Frequency Nominal 60 Hz  $\pm$  5%

Temperature -40°F to +131°F (ambient)

Humidity 0% to 100 % (non-condensing)

### General performance characteristics

Starting current 100mA

Creep 0.000 A (no current) No more than 1 pulse measured per quantity, conforming to ANSI C12.1 requirements

Burden Less than 1.5W

Primary time base Relative time is maintained by a crystal, real time is provided by the EnergyAxis network

Communications frequency 902 MHz to 928 MHz (unlicensed)

Communications rate 17,600 bps (900 MHz radio)

IEC standards compliance IEC 62052-11, IEC 62052-21, IEC 62053-21

Additional standards C12.19, C12.22, AS/NZS 4268, NMI M6

Ordering # 1C3471

### Front of Enclosure

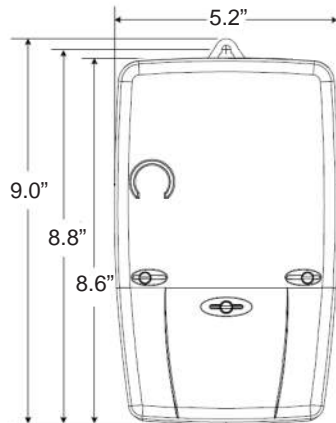

### Side of Enclosure

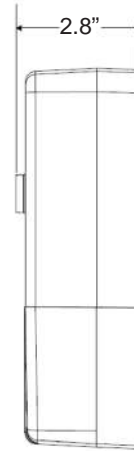

### Simple Installation

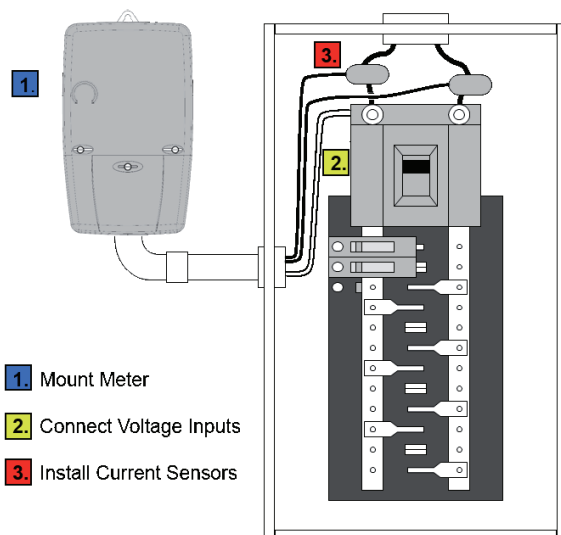

- 1.** Mount Meter
- 2.** Connect Voltage Inputs
- 3.** Install Current Sensors

### Split Core Transformer



Information contained herein is subject to change without notice. Product specifications may change. Contact your Byram representative for the most current product information. Printed in the United States.

EnergyAxis is a trademarks and/or registered trademark of Elster. Used by permission. Other products may be trademarks and/or registered trademarks of their respective owners.